

Entertainer Pro XL Bluetooth Speaker

Operating Instructions



Overview

This portable PA speaker system has been designed for indoor and outdoor entertaining with coloured LED lighting to add to the party atmosphere. It is the perfect speaker to set up anywhere you need instant sound. Powered by an internal, rechargeable lithium battery, it provides up to 3-8 hours of use depending on volume level. The unit is True Wireless Stereo (TWS) enabled, allowing you to synchronise two speaker units via Bluetooth for stereo sound. Stream audio wirelessly from any Bluetooth enabled device, or play MP3 audio from the USB port or Micro SD card slot. Microphone audio can also be recorded to connected USB or Micro SD memory sticks. With the included wireless microphone, you can easily make speeches or perform your own home karaoke accompanied by your favourite tunes.

Features

User Friendly: Simple plug and play interface to manage multiple inputs.

Bluetooth (Version 5.0): Stream audio wirelessly from any Bluetooth enabled device.

TWS: Pairs two speakers via Bluetooth to play the same music in stereo, or dual mono for mics.

Wireless Microphone: Independent volume and echo controls located on speaker console.

Wired Microphone Input: Shares the console controls with the wireless mono mic.

USB port and Micro SD card slot: Access MP3 music stored on portable memory devices.

Digital Recorder: Record the microphones' audio directly onto your USB drive or SD card.

AUX Input: Plug and play smart phones, tablets and MP3 players connected via 3.5mm stereo jack.

FM Radio: Analogue FM band scanner with digital tuning dial.

Master Controls: Regulate audio volume, bass and treble, for all input sources.

Power Source: Large internal rechargeable lithium battery for portability and long play times.

Party Lights: Exciting lighting effects with multiple colours that sync to the audio.

Panel Function Description

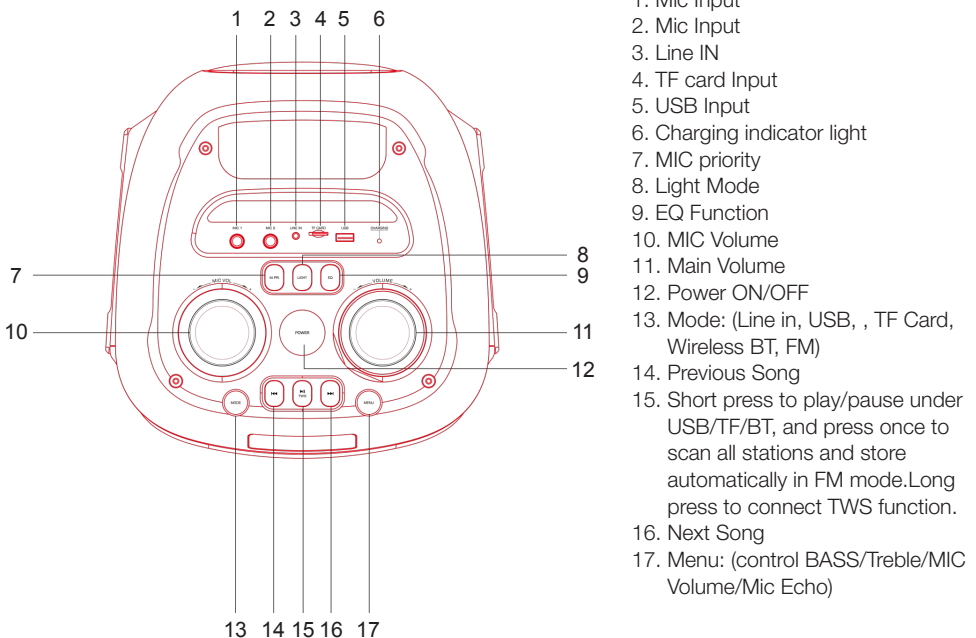

Remote Control Functions

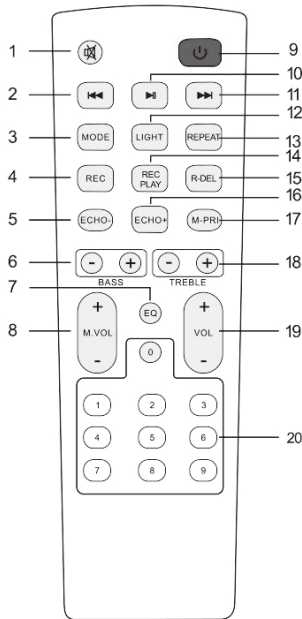

1. **Mute**
2. **Previous Song:** Short press to get previous sound(under USB/TF/BT/FM mode), long press to fast backward (under USB/TF mode).
3. **Mode:** Short press to skip to BT/LINE IN/USB/TF/FM mode.
4. **Record function:** Under USB/TF mode, press the “REC” button to start/stop recording. Press play/ pause to pause or resume recordings.
5. **Echo-:** Press to decrease the echo in any mode.
6. **BASS+/-:** Press to increase or decrease the bass.
7. **EQ function:** Press to select different EQ settings.
8. **Microphone Volume+/-:** Press to increase or decrease the microphone volume.
9. **Power by**
10. **Pause & Play:** Short press to play/pause(Under USB/TF/BT), Long press to connect TWS,and press once to scan all stations and store automatically in FM mode.
11. **Next song:** Short press to get next song(under USB/TF/BT/FM mode), long press to fast forward (under USB/TF mode).
12. **Light mode:** Light effect switch and on/off.
13. **Repeat function:** Press to repeat one song or repeat all songs (under USB/TF).
14. **Record play:** In USB/TF mode, press to play the recording.
15. **Record delete:** In USB/TF mode, press to delete the recording.
16. **Echo+:** Press to increase the Echo in any mode.
17. **Microphone priority:** When the Microphone is in use, press once to take priority over the music programme, press again to turn off this function.
18. **Treble+/-:** Press to increase or decrease the treble in any mode.
19. **Main Volume**
20. **Number buttons:** Use under USB/TF mode to choose songs. In FM mode you can choose the received station

Operating Instructions

Bluetooth Pairing Mode

Press MODE button on the unit or the remote control until Bluetooth is selected

1. Ensure your device is within 10m of the speaker
2. Activate the Bluetooth features on your device so that the device starts to search for the speaker.
3. Select the correct model No.: (C5162).
4. Short press “⏸” key to play or pause music. Short press “⏮” or “⏭” key to select the previous or next track.

LINE IN Mode:

1. Press the MODE button on the unit or the remote control until the LINE is selected.
2. Connect source via aux cable.
3. Play the music of the device connected to the LINE input.

USB/TF CARD Mode:

1. After start-up, press mode button to select ‘USB or TF card’ mode, or insert the USB or TF card in this speaker, the unit will play the songs automatically.
2. Press “⏸” key shortly to pause or play.
3. Shortly press “⏮” key to the previous song.
4. Shortly press “⏭” key to the next song.

FM Mode

1. Turn on the power and press the MODE button repeatedly to select the FM function (the frequency is displayed on the display).
2. Press the play button to activate the automatic memorization function (the tuner searches for available stations and memorizes automatically).
Note: The number of memorized stations depends on the reception in your area.
3. Use the next/previous buttons to listen to the memorized stations.
4. To select a memorized station directly, press the corresponding numeric key on the remote control.

TWS Mode

The two speakers can connect to each other in TWS mode.

1. Place the two TWS speakers near each other (the distance should not be over 10 meters).
2. Power on the two speakers, both speakers selected to Bluetooth mode, press and hold for about 5 seconds the TWS button on one speakers as master speaker, TWS connection will be built up.
3. In TWS mode, press and hold TWS button for about 5 seconds on either speaker or power off the speaker to exit the TWS mode.

Specifications

General Specifications:

Power:	40W RMS
Size:	2 x 6.5" woofer + 1" tweeter
Battery:	7.4V/3600mA
Function:	EQ selection, microphone priority, recording, TWS function
Feature:	LED light, LED display
Accessories:	Remote control, user manual, power cable, microphone

Troubleshooting

Fault	Simple Fault Analysis	Probable Solutions
No Power LED Lit Up	<ol style="list-style-type: none"> 1. The power switch is not on. 2. Built-in battery is discharged. 	<ol style="list-style-type: none"> 1. Turn power switch on. 2. Use power adapter to charge the battery.
No Sound - Bluetooth, Digital Media, Aux, FM	<ol style="list-style-type: none"> 1. Failing to input sound source. 2. Failing to establish Bluetooth signal line. 3. Master volume switched to minimum. 4. USB/SD card has no audio. 5. Faults with external AUX signal source. 6. FM station has no audio/only static. 	<ol style="list-style-type: none"> 1. Use MODE / Toggle to Change signal source. 2. Turn off and back on, then reconnect bluetooth speaker. 3. Properly adjust the master volume knob. 4. Inspect USB disk / SD Card on a PC. 5. Readjust or change AUX signal line/cable. 6. Check the frequency or check another preset station or rescan.
No Sound - External Wired Microphone	<ol style="list-style-type: none"> 1. External microphone mono plug is not fully inserted into the socket. 2. The external microphones switch is off. 3. The microphones volume is too low. 	<ol style="list-style-type: none"> 1. Reinsert the microphone cable to the mic socket. 2. Turn the external microphones switch on. 3. Properly adjust the microphones volume fader on the console.
No Sound - Wireless Microphone	<ol style="list-style-type: none"> 1. Microphones switch is off. 2. Microphones switch is on but no sound. 	<ol style="list-style-type: none"> 1. Turn on the microphone switch. 2. Check phone battery levels mic and replace battery if needed.

NOTE: If there is still a fault after the inspection above, please refer to the warranty page at the back of this manual. **This unit contains no user-serviceable parts inside. DO NOT OPEN.**

Safety Information

- Read all warnings.
- Follow all instructions.
- The speaker must not be exposed to dripping or splashing liquids and no objects filled with liquids such as vases, water bottles, or cups should be placed on it.
- Clean using a soft, damp cloth. Do not use liquids or sprays directly on the unit's surface.
- Do not block any ventilation openings. Minimum distance of 30cm around the speaker must be maintained.
- Do not rest this speaker near any heat sources such as heat registers, radiators, stoves, or other heat generating appliances (including amplifiers).
- Keep away from all open flame sources, such as lighted candles, which should never be placed on or near the speaker.
- Only keep the adapter or power cord plugged into the speaker while charging. Once charged, unplug it.
- Do not charge the speaker during lightning storms.
- Protect the power cord from being walked on or pinched, particularly where it attaches to the speaker or the electrical socket.
- Only use attachments/accessories specified by the manufacturer.

DYNALINK Entertainer Pro XL Bluetooth Speaker

Altronic Distributors warrants this product for one year from date of purchase from Altronics or its resellers to the consumer. If this item is part of an installation or another product, please contact the installer or supplier for your warranty.

During the warranty period, we undertake to repair or replace your product at no charge if found to be defective due to a manufacturing fault. The warranty excludes damage by misuse or incorrect installation (i.e. failure to install and operate device according to specifications in the supplied instruction manual), neglect, shipping accident, or no fault found, nor by use in a way or manner not intended by the supplier.

For repair or service please contact your **PLACE OF PURCHASE**.

If this item was purchased directly from Altronics please make a warranty claim by:

1. FOR MAIL ORDER CUSTOMERS (includes school and trade orders),

a) Calling your nearest store location and quoting your tax invoice number.

b) Upon contacting Altronics, we will issue an R.A. (Return Authorisation). As Altronics have a number of service agents throughout Australia, a copy of the R.A. will be emailed, faxed or mailed to you with full instructions of how and where to send the goods. The freight for shipping goods back to Altronics for all repairs is at the customers expense.

c) A copy of the R.A. form, (or at the very minimum, the R.A. number) must accompany the goods to effect the repair.

d) Altronics will pay the return freight to the customer where the warranty claim has been accepted.

e) Please quote the R.A. number in any correspondence to us.

2. FOR OVER THE COUNTER PURCHASES to make a warranty claim, please return the goods to us in any of our stores, with a copy of your proof of purchase (tax invoice).

a) Upon leaving the goods at one of our stores, an R.A. number will be issued to you.

b) Once repaired, you will be contacted, advising that the goods are ready to be collected from the store.

It is at Altronics discretion as to whether the goods will be repaired or replaced (whilst under warranty); and as to whether identical goods will be used to replace the item due to changes of models / products.

Note: Under no circumstances should you attempt to repair the device yourself or via a non-authorized Altronics service centre, as this will invalidate the warranty!

Our goods come with guarantees that cannot be excluded under the Australian Consumer Law. You are entitled to a replacement or refund for a major failure and for compensation for any other reasonably foreseeable loss or damage. You are also entitled to have the goods repaired or replaced if the goods fail to be of acceptable quality and the failure does not amount to a major failure.